

CUC NEWSLETTER

SUMMER, WEEK 4

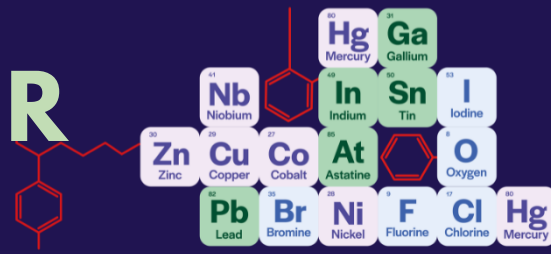

This week we have been inspired by Arabic culture. Students have had many opportunities to learn more about Arabic culture and celebrate the diversity within our community. It has been both wonderful to learn and to share our experiences. Students have enjoyed a visit from an Arabic artist, participated in an Arabic art competition, visited an Arabian tent and shared an Arabic tasting menu. Students also had the chance to learn about Arabic contributions to the field of science, maths, art, languages, astronomy, horticulture and medicine. Thank you to our student ambassadors for sharing their culture and to staff for making this possible.



Students were invited to attend in their traditional clothes. Our ambassadors looked incredible and spoke confidently about the significance of these clothes to their heritage.

Ignite enjoyed an Arabic meal together and all other year groups were offered a tasting selection of foods to explore.



As part of our Arabic week, we've welcomed local, self-taught Lebanese artist, Hassan Ismail to the CUC. Hassan discovered his passion for art as an escape in the mist of war when he was 6 years old. He spoke about Lebanese culture and shared some of his work.

Useful Dates -

- 18th May - Virtual Open Evening
- 26th May - End of half term
- 5th June - Return to school

Word of the Week - AUDACIOUS

Definition: showing a willingness to take bold risks:

Usage: "a series of audacious takeovers"

Definition: showing an impudent lack of respect:

Usage: "he made an audacious remark"

Zero Tolerance of Abuse - The NST has a zero-tolerance approach towards abusive language, violence, aggression or harassment towards our employees, governors and volunteers.

Info about exams from Ofqual - Dr Jo Saxton, Chief Regulator at Ofqual, regulator of qualifications, exams and assessments has written to parents detailing additional support that is in place this year for students taking exams to recognise the disruption they've faced. Read the letter in full at <https://www.gov.uk/government/publications/letter-to-parents-april-2023/letter-to-parents-april-2023>

Student Leaders - This week the student leaders had a meeting to discuss new upcoming experiences they would like to have, as well as planning culture day which took place during the Arabic lunch. The students dressed up in their cultural dress and spoke about their individual cultures. They looked amazing and expressed themselves so well.



Mental Health Awareness Week takes place from Monday 15 – Sunday 21 May 2023. Mental Health Awareness Week is an ideal time for us all to think about mental health, tackle stigma, and find out how we can create a society that prevents mental health problems from developing and protects our mental well-being. Anxiety is common. Find out ways to manage feelings of anxiety and prevent them from getting worse at www.mentalhealth.org.uk/mhaw
More information here: <https://www.mentalhealth.org.uk/our-work/public-engagement/mental-health-awareness-week>



YPAS LGBTQ+ groups are doing a 'Mental Health May' across all groups with bitesize taster sessions including anxiety and breathing, as well as a chance to reduce isolation and make LGBTQ+ friends. For more info, email gyro@ypas.org.uk or get in touch with @ypasliverpool and @gyroliverpool on Instagram.



Social Sciences - Ignite students have been learning about the jam jar theory when investigating mental health and depression. The students explored how genetics and environmental contribute to mental health and how protective factors such as friends, family, exercise, diet, sleep, mindfulness, therapy keep our mental health in a positive place. Students then made their own jam jars to pass on to someone they care about whilst explaining the theory behind the jars. If you received a jam jar from your child I hope they explained the theory to you as well !

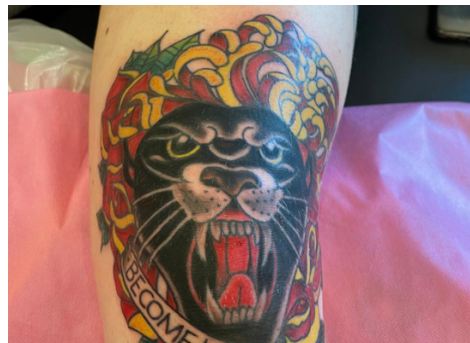

Creatives - This week, Year 12 had a visit from alumni student Jess Pearson who talked about her experience of getting into the Tattoo industry.

History - Ignite have been studying the Battle of the Somme. Year 10 have studied the Essex Rebellion. Year 12 have been studying Russian Anti Semitism in the 19th century.

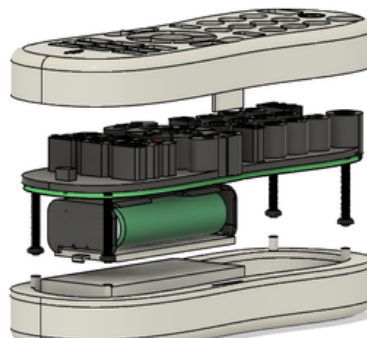
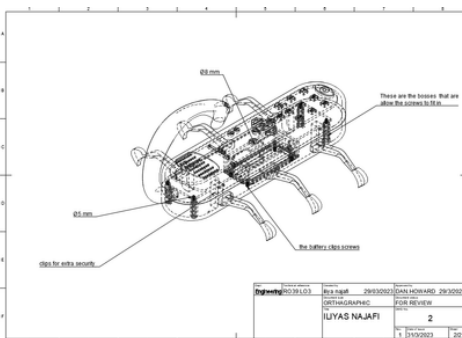

Engineering - Year 10 have now finished their remote control designs and images show a taste of some of their work. They have used Autodesk Fusion 360 design software to 3D model their designs and then produce technical drawings in line with BS8888. these are real industry standards and industry leading software that we use to teach our students.

Social Sciences Pathway - We are in the process of securing summer school and work experience placements. We have two students with placements in architecture firms and students who have been accepted onto the UCL, University of Leicester summer and St Andrews summer school programme. These will be such exciting opportunities for the students!